

MANUAL MODE



In some start-up conditions may be useful to work in "manual" mode:
 Power off the processor, press **+** key and keep it pressed giving power on: **HAnd** message will be displayed (release now **+** key).
 Push **+** until is displayed number required to be handed (see table *State indication lamps*) and push **ALARM** for activating relay.
 Pushing again **+** for increase relay number previous relay is deactivated.
 You can press **ALARM** key for a least two seconds to escape and return to the *Run Mode*.

PRESET PROGRAMS (Bootstrap).



This processor is already programmed with the following (variable) settings.
 To return to these settings at any time you may:
 Power off the processor, press **ALARM** key and keep it pressed giving power on: **boot** message will be displayed (release now **MAX VENT** key).
t.SET = 37.7° H.SET = 80.0H AL._ = 37.2 AL.-- = 38.0
 The **COST** values are shown in **COST** paragraphs.

INSTALLATION

How to connect the line.

Connect 220V line on terminals **L-N**.
 Protect supply with adequate fuse.

How to connect the contacts.

Connect terminals on the terminal block (contacts up to 4AMP.AC1) to the loads as shown in the diagram.

How to connect the sensors

Connect the provided sensor as shown in the diagram.

For remote connections use a standard 0.5-square millimeter two-pole wire (one for each sensor), taking great care over the connections, by insulating and sealing the joins carefully. **-O.C.-** is displayed when the temperature sensor wiring is open, **-S.C.-** is displayed when the temperature sensor wiring is short circuit.

How to connect humidity-psychrometer system (wet bulb).

Opt.H=1 psychrometer system humidity connection.

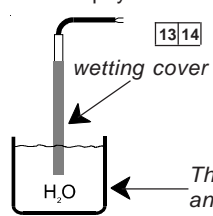

SXPS: temperature probe for wet bulb (psychrometric system). Attention: deep only the terminal side of the wetting cover.

This water-container is not an item of our production.

How to connect 4-20mA electronic humidity probe.

Opt.H=2 electronic humidity probe connection.

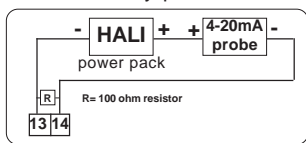

4-20mA sensor probe connection

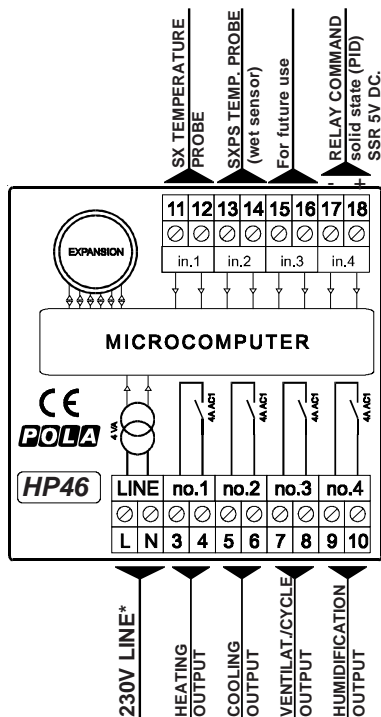

* Other power voltage if you required.

HP46

SL 6.0

Egg-Discloser

Handbook

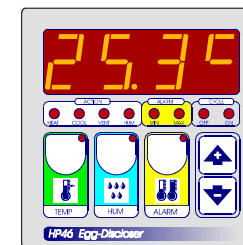

MAIN SETTING (Run Mode)

TEMPERATURE SETTING



Press **TEMP** (key lamp flashes):
 this message will be displayed instead of the ° Set temperature value .
 Press **+** or **-** to modify, press **TEMP** to confirm.

F.5E7

HUMIDITY SETTING.



Press **HUM** (key lamp flashes):
 this message will be displayed instead of the %RH Set Humidity value .
 Press **+** or **-** to modify, press **HUM** to confirm.

H.5E7

VIEW OF ALARM SETTINGS.



The settings of alarm temperatures can be only see on display; to obtain this press **ALARM** (key lamp flashes):
 this message will be displayed instead of the ° Set Minimum alarm temperature value .

AL. _ _

Press **ALARM** : at this point this message will be displayed instead of the ° Set Maximum alarm temperature value .
 Press **ALARM** to exit.

AL. _ _

AMBIENT TEMPERATURE AND HUMIDITY VIEWING



With **TEMP** key lamp light (press **TEMP** key) ambient temperature is displayed. With **HUM** key lamp light (press **HUM**) ambient humidity is displayed (if the humidity is obtained with "wet bulb" , pressing **HUM** for more than 1 second on display will appear the message **t.vEt** in turn of obtained value of temperature probe "wet bulb".

VIEWING TEMPERATURE RECORDING



Press **+** : will be displayed followed by °Maximum Temperature Recording.

Press **-** : will be displayed followed by °Minimum Temperature Recording.

Values are permanently stored in the memory: for deleting all values in the memory keep pushed **+** key for more than 3 seconds: **CLEA** message will appear on display before clearing operation.

COST PROGRAMMING (System constants)



These settings refer to the operation mode of the system and must be made on initial startup. Press - / + at the same time for at least one second: the message **C.O.S.t.** will be displayed.

Press then repeatedly **ALARM** until the message regarding the chosen variable is displayed (see table below) : value of variable and message will be displayed. Press + or - to set a new value and then press **ALARM** to confirm.

The next system constant will then appear.

You can press **ALARM** for at least 2 seconds to exit and return to the Run Mode.

r.HEA	-0.2°	°C HEAT setting shift referring to t.SET.	*1
r.vEn	0.2°	°C VENT setting shift referring to t.SET.	*1
r.COL	0.4°	°C COOL setting shift referring to t.SET.	*1
d.HEA	0.2°	°C HEAT differential.	*1
d.vEn	0.2°	°C VENT differential.	*1
d.COL	0.2°	°C COOL differential.	*1
r.AL_	-0.5°	°C MIN ALARM setting shift referring to t.SET.	*1
r.AL-	0.3°	°C MAX ALARM setting shift referring to t.SET.	*1
CYCL	0	Number of daily cycles/VENT exclusion	*2
durA	0'	Minutes ON duration of daily cycles	*2
ProP	1.0°	°C HEAT PID proportional band.	*3
IntE	8.0"	Time seconds of cycle and of PID integration.	*3
dEri	4.0"	Time seconds of PID derivative.	*3
SELF	=1	Autotuning (=0 disable, =1 enable).	*4
b.Hun	2.0H	%RH humidification proportional band	*1
CYC.H	0"	Seconds of humidification cycle.	*1
Set_	35.0°	°C minimum set (t.SET) impostation.	*5
Set-	38.2°	°C maximum set (t.SET) impostation.	*5
Opt.H	=1	Humidity sensor type	*6
tEnP	=1	Temperature representation (=1 °C, =2 °F).	*7
Ad.tE	0.0°	°C Input temperature sensor correction (+ or -).	*7
Ad.tu	0.0°	°C Input temperature wet sensor correction (+ or -).	*7
Ad.rH	0.0H	%Rh Input humidity sensor correction (+ or -).	*7

*1) For more details see *Operating Diagrams*.

*2) If **CYCL=0** relay N.3 works as VENTILATION output (indicated by VENT lamp). If **CYCL=1** (1 cycle/day) to **CYCL=1720** (period cycle 2 minutes) VENTILATION operations are excluded and CYCLE timer lamps lights indicating status of relay N.3 (closed during ON duration). CYCLE timer is saved in order to continue counting after line blackout.

*3) PID function with exit on **17-18** terminals to control of one solid-state relay (**SSR**).

*4) Referred to PID function. The correction of autotuning is set every 16 x **IntE**.

*5) The temperature setting that can be programmed with TEMP key must be included among these values.

*6) **Opt.H=1** : psychrometric sistem (wet bulb): to call for a **SXPS** probe.

Opt.H=2 : 4-20mA sensor: to call for a **HALI** power pack.

The psychrometer-system obtained value can be recognized with the classic curve.

*7) You can correct the readings on the sensor (+ or -).

STATE INDICATION LAMPS

The light situated at the bottom of the display shows the state of the controller:

Lamp.	State	N° Relay	Contacts
HEAT	HEAT ON output	1	3-4
COOL	COOL output	2	5-6
VENT	VENT ON output	3 ^{*1}	7-8
HUM	HUM ON output	4	9-10
MIN ALARM	MIN ALARM ON output	6 ^{*2}	3-4-5 *
MAX ALARM	MAX ALARM ON output	7 ^{*2}	6-7-8 *
CYCLE OFF	CYCLE OFF output	3 ^{*1}	7-8
CYCLE ON	CYCLE ON output	3 ^{*1}	7-8

*1 If **CYCL=0** (see COST) relay N.3 works as VENTILATION output (indicated by VENT lamp).

If **CYCL=1** (1 cycle/day) to **CYCL=1720** (period cycle 2 minutes) VENTILATION operations are excluded and CYCLE timer lamps lights indicating status of relay N.3 (closed during ON duration). CYCLE timer is saved in order to continue counting after line blackout.

*2 Available only with **HPAL** optional slot.

OPERATIVE DIAGRAMS

Function on the ground of the temperature.

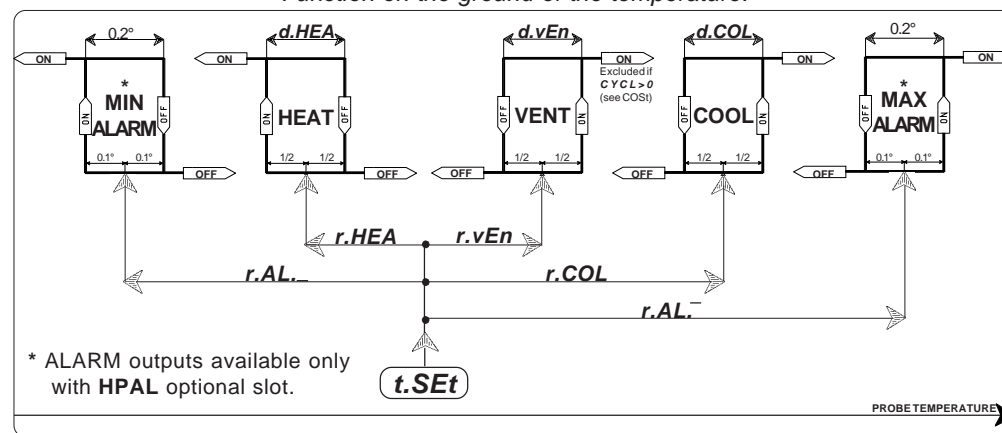

Function on the ground of the humidity.

